

XR75CX Case Display I/O Installation and Operation Manual





Retail Solutions
3240 Town Point Drive NW Suite 100
Kennesaw, GA 30144 USA

Phone: **770-425-2724**
Fax: 770-425-9319

TABLE OF CONTENTS

1 INTRODUCTION	1
1.1. GENERAL WARNING	1
2 OVERVIEW	1
2.1. GENERAL DESCRIPTION	1
2.2. X-REP OUTPUT (OPTIONAL).....	2
2.3. ORDERING CODE	2
3 CASE DISPLAY OUTPUTS	3
4 E2 SETUP	4
4.1. CONFIGURING THE XR75CX-CD THROUGH E2	4
4.2. E2 CIRCUIT ASSOCIATION	4
5 OPERATION	5
5.1. OUTPUT RELAY CONTROL.....	5
5.2. MODES OF OPERATION	5
5.3. DEFROST MODE.....	5
5.4. E2 ALARMS (CASE TEMP HI AND CASE TEMP LO).....	5
6 FRONT PANEL COMMANDS	6
6.1. KEYS AND FUNCTIONS	6
6.2. USE OF LEDS	6
7 MAIN FUNCTIONS	7
7.1. SETTING THE BAUD RATE AND ADDRESS	7
7.2. HOW TO ASSIGN A MODBUS ADDRESS.....	7
7.3. THE ON/OFF FUNCTION	7
8 PARAMETERS	8
9 DIGITAL INPUTS	9
9.1. ON - OFF FUNCTION.....	9
9.2. DIGITAL INPUTS POLARITY	9
10 INSTALLATION AND MOUNTING	9
11 ELECTRICAL CONNECTIONS	10
11.1. PROBE CONNECTION.....	10
12 HOW TO USE THE HOT KEY	10
13 SPECIFICATIONS	11
14 CONNECTIONS	12
15 E2 MODBUS NETWORK WIRING	13
16 ECT MODBUS NETWORKING TO E2S	14
16.1. COM PORT ASSOCIATIONS - E2 VERSIONS 3.XX AND BELOW	14
16.2. COM PORT ASSOCIATIONS - E2 VERSIONS 4.2 AND ABOVE.....	14
16.3. E2 SETUP OF DEVICES.....	15
16.3.1. Set Up Network Ports.....	15

16.3.2. <i>Add and Connect the Device</i>	15
16.4. WIRING TYPES	17
16.5. MODBUS TERMINATION BLOCKS	17

1 Introduction

1.1. General Warning

Please read the following safety precautions and warnings before using this manual:



CAUTION!

- *This manual is part of the product and should be kept near the device for easy and quick reference.*
- *The device should not be used for purposes different from those described in this manual. It cannot be used as a safety device.*
- *Check the application limits before proceeding.*



SAFETY PRECAUTIONS AND WARNINGS!

- *Check that the supply voltage is correct before connecting the device.*
- *Do not expose to water or moisture: use the controller only within the operating limits and avoid sudden temperature changes with high atmospheric humidity to prevent condensation from forming.*
- *Warning! Disconnect all electrical connections before performing any kind of maintenance.*
- *Fit the probe where it is not accessible by the end user. The device must not be opened.*
- *In case of failure or faulty operation, send the device back to the distributor or to Retail Solutions (see address) with a detailed description of the fault.*
- *Verify the maximum current that can be applied to each relay (see Section 13, Specifications).*
- *Ensure that the wires for probes, loads, and the power supply are separated and far enough from each other without crossing or intertwining.*
- *In case of applications in industrial environments, the use of main filters (our mod. FT1) in parallel with inductive loads could be useful.*

2 Overview

2.1. General Description

The XR75CX-Case Display (32 mm x 74 mm) is a microprocessor based controller, suitable for applications on medium or low temperature ventilated refrigeration units. It has up to four (4) analog inputs: discharge air temperature, product temperature, defrost temperature and coil out temperature, four (4) relay outputs, and up to two (2) digital inputs.

The Case Display displays these temperatures and values on an LED display. Case Display may be networked with an E2 RX controller (software version 3.02 or higher) to share sensor data with a Standard Circuit application that controls the case refrigeration.

Because the Case Display requires only a single network cable to communicate with an E2, cases equipped with XR75CX-CDs require significantly less wiring and installation labor than traditional installations (which typically require one cable per sensor run to a centrally located group of input boards).

The XR75CX-CD may control 4 external loads directly from its 4 onboard dry-contact relay outputs.

The RS-485 serial output enables the unit to be connected to a network line that is MODBUS-RTU compatible.

Two Modes of Operation

The XR75CX-CD can operate in Normal mode and Standalone (failsafe) mode. When the case display is communicating normally with the E2, it is operating in Normal mode. If the communication between the case display and the E2 is interrupted, the case display will go into Standalone (failsafe) mode.

2.2. X-REP Output (Optional)

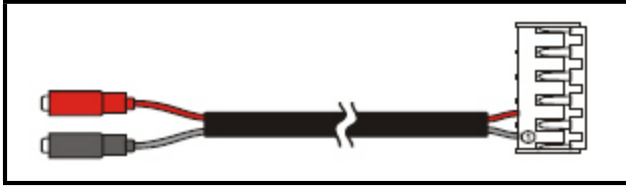

Figure 2-1 - X-REP Output

To connect the X-REP to the controller, the following connectors must be used:

Description	Part Number
XREP Cable 1 meter	318-7211
XREP Cable 2 meter	318-7212
XREP Cable 3 meter	318-7215

Table 2-1 - Wire Specifications

2.3. Ordering Codes

Device Name	Emerson Part Number
XR75 Case Display - 110 VAC RED LED	318-6040
XR75 Case Display - 230 VAC RED LED	318-6041
XR75 Case Display - 110 VAC BLUE LED	318-6050
XR75 Case Display - 230 VAC BLUE LED	318-6051
XREP RED LED	318-7210
XREP BLUE LED	318-7220
XREP Cable 1 meter	318-7211
XREP Cable 2 meter	318-7212
XREP Cable 3 meter	318-7215
XREP Mounting Plate	303-6037
XR75 Kit, Case Display - 110 VAC RED LED	818-6040
XR75 Kit, Case Display - 230 VAC RED LED	818-6041
XR75 Kit, Case Display - 110 VAC BLUE LED	818-6050
XR75 Kit, Case Display - 230 VAC BLUE LED	818-6051
XR75 Manual	026-1217

Table 2-2 - Product Ordering Code

3 Case Display Outputs

On-Board Relay Outputs





The XR75CX-CD has 4 on-board relays that may be used as satellite outputs by other E2 applications. Wire the outputs to the two-wire terminals on the right side of the control unit. For loads greater than 3A, use the outputs to energize external relays.

Output	Terminal #	Resistive Rating @250VAC
OS1	1 and 3	120/240 4.9FLA, 29.4 LRA, 10A
OS2	1 and 7 or 1 and 8	N.O./N.C- 120/240 10A
OS3	1 and 4	120/240 5A
OS4	1 and 2	120/240 ¼ HP, 10A

Table 3-1 - Output Ratings



4 E2 Setup



4.1. Configuring the XR75CX-CD Through E2

1. While logged in to the E2 with Level 4 access, press  - CONFIGURED APPLICATIONS.
2. Select "100. XR75CX-CD"
3. If there are multiple XR75CX-CDs, highlight the application name whose number corresponds to the network address of the XR75CX-CD you wish to set up (i.e., "XR75CX-CD" for XR75CX-CD #1).
4. From the XR75CX-CD's status screen, press  - SETUP.
5. The parameters in these setup screens can be used to specify which inputs are present, the case name or defrost override message, sensor offsets, and other important functions. The E2 Online Help will explain the function of each parameter - to access Online Help, highlight the parameter you need assistance with, and press .
6. When all parameters are set properly, press  to return to the XR75CX-CD's status screen.

4.2. E2 Circuit Association

The final step in setting up an E2 MODBUS network with XR75CX-CDs is associating the Standard Circuit applications in the E2 with the XR75CX-CDs they are attached to. Refer to the E2 user manual for information on how to add and configure standard circuits.

1. Log in to the E2 with level 4 access.
2. Press  - CIRCUITS to view the circuit summary screen.
3. Highlight the circuit you wish to configure, then press  - SETUP.
4. In Setup screen *C1: General*, set the following two parameters:
 - **Num Case Sensrs:** Enter the number of XR75CX-CDs on this circuit.
 - **Num Prod Sensrs:** If the XR75CX-CDs on this circuit have sensors on input #2, enter the number of these sensors.
 - **Using Case Disp:** Set to **Yes**, indicating the case temperature and other temps related to this circuit are being supplied by XR75CX-CDs.

5. Press  to move to Setup screen *C2: Case Disp*. This screen will show a number of Case Display fields equal to the number entered in Num Case Sensrs (step 4). For each field, press  - LOOK UP and select the application name whose number corresponds to the network address number of the XR75CX-CD you want to associate. For example, if you want to associate XR75CX-CD #7 with this circuit, select **CL CD007** from the Look-Up Table.

Once associated, the Standard Circuit will automatically receive discharge air, termination temperature, and product temperature (either by sensor or calculation) from the XR75CX-CDs.

5 Operation

5.1. Output Relay Control

The 4 on-board relays on the XR75CX-CD are controlled by the associated XR75CX-CD application in the E2. To control these relays, you must connect the application's RELAY x COMMAND input (where x is the relay number) to the output of another application in the E2 (such as a schedule to control lighting). Refer to the E2 Manual, *P/N 026-1610*, for information on setting up input definitions.

5.2. Modes of Operation

Case Temperature Display (Normal Mode)

When the case circuit is not in defrost and no alarms are active, the XR75CX-CD display shows a temperature. The user may select any of the four temperature inputs on the XR75CX-CD as the default display temperature (by default, the XR75CX-CD shows the discharge air temperature).

In this mode, you may view the values of all the other inputs and outputs by pressing the DOWN arrow button. Each time the DOWN arrow button is pressed, a message will be displayed for one second to indicate what input or output value will be shown, followed by the current value

5.3. Defrost Mode

When the case circuit is in defrost (driven by the standard circuit), the XR75CX-CD may be programmed to display any three-character message instead of the default temperature. This feature ensures the higher case temperatures that occur during a defrost cycle do not alarm customers. The defrost message is displayed throughout the defrost cycle and for a programmed amount of time afterwards.

5.4. E2 Alarms (Case Temp Hi and Case Temp Lo)

When a XR75CX-CD is associated with a Standard Circuit application in E2, a “Case Temp Hi Limit Exceeded” or “Case Temp Lo Limit Exceeded” alarm that occurs for the XR75CX-CD's associated case will cause the main module and remote display's Alarm LED to turn ON, indicating an active alarm. Unlike XR75CX-CD's temperature sensor alarms, no alarm message will be shown on the display when case temperature alarms occur.

6 Front Panel Commands



Figure 6-1 - XR75CX-CD Front Panel

Once the XR75CX-CD has been powered up for several minutes, programming from the front panel is disabled. Address and baud rate must be configured with the first minute of powering the device.

6.1. Keys and Functions

Table 6-1 shows the keys that are found on the front panel of the XR75CX-CD controller and their corresponding functions:





Key	Function
SET	Press to display target setpoint, to select a parameter in programming mode, or to confirm an operation
	Press the UP arrow to see the MAX temperature, to browse the parameter codes in programming mode, or to increase the currently displayed temperature value.
	Press the DOWN arrow to see the MIN temperature, to browse the parameter codes in programming mode, or to decrease the currently displayed temperature value.
	Switches the device ON and OFF
SET + 	To enter programming mode
SET + 	Returns to room temperature display

Table 6-1 - XR75CX-CD Front Panel Keys and Functions

6.2. Use of LEDs

Each LED function is described in Table 6-2:





LED	Mode	Function
	ON	CASE STATE = Refrigeration
	ON	CASE STATE = Defrost
	Flashing	CASE STATE = Drip
	ON	ALARM output = ACTIVE
	ON	CASE STATE = Recovery

Table 6-2 - LEDs

7 Main Functions

7.1. Setting the Baud Rate and Address

To change the parameter's value follow these steps:

1. Enter the Programming mode by pressing the SET + DOWN arrow keys for 3 seconds (the °C or °F LED starts blinking).
2. Press the down arrow until **adr** displays.
3. Press the SET key.
4. Press the down arrow until **bAu** displays.
5. Use the UP and DOWN arrow keys to scroll through the available baud rate choices and select 19200.
6. Press SET to save.



***NOTE:** The set value is stored even when the time-out expires and ends the procedure.*

The E2 will override values set at the XR75CX Case Display device.

7.2. How to Assign a MODBUS Address

1. Follow steps 1 and 2 of **Section 7.1., Setting the Baud Rate and Address** to access the Address Setup Menu.
2. Select the **Adr** parameter.
3. Press SET to select.
4. Choose the address number using the arrow keys and press SET again to save.
5. Press SET and UP arrow keys to exit.

8 Parameters

This parameter table is a reference for changing parameters in the device, but the E2 controller will override any changes made at the device.

Code	Parameter	Function
Adr	Serial address	1 to 247
PbC	Kind of probe	CtC(0) - ntC(1)
odA	Air probe calibration	[-12.0°C to 12.0°C] [-21°F to 21°F]
Pr	Product probe presence	n(0) - Y(1)
oPr	Product probe calibration	[-12.0°C to 12.0°C] [-21°F to 21°F]
Co	Coil outlet probe presence	n(0) - Y(1)
oCo	Coil outlet probe calibration	[-12.0°C to 12.0°C] [-21°F to 21°F]
dF	Defrost probe presence	n(0) - Y(1)
odF	Defrost probe calibration	[-12.0°C to 12.0°C] [-21°F to 21°F]
CF	Temperature measurement unit	°C(0) - °F(1)
rES	Resolution	dE(0) - in(1)
dSP	Display type : local or remote	LoC(0) - E2(1)
Lod	Probe displayed	dA(0) - Pr(1) - Co(2) - dF(3)
dLy	Display temperature delay	0 to 20M0 (120) (10 sec.)
oS1	Output 1 status in Stand Alone mode	oFF(0) - on(1) - LSt(2)
oS2	Output 2 status in Stand Alone mode	oFF(0) - on(1) - LSt(2)
oS3	Output 3 status in Stand Alone mode	oFF(0) - on(1) - LSt(2)
oS4	Output 4 status in Stand Alone mode	oFF(0) - on(1) - LSt(2)
oS5	Output 5 status in Stand Alone mode	oFF(0) - on(1) - LSt(2)
i1P	Digital input 1 polarity	OP(0) - CL(1)
i2P	Digital input 2 polarity	OP(0) - CL(1)
CoM	Time for Stand Alone mode	10 to 255 sec
rEL	Firmware Release	read only
Ptb	Map code	read only
.dsPR2	Pr2 access disabling after the first minute	0=no 1=yes
.eLock	Lock keyboard enabling	0=no 1=yes

Table 8-1 - List of Parameters

9 Digital Inputs

The first digital input 18-20 is enabled with **P3P = n**.

With **P3P = n** and **i1F = i2F**, the second digital input is disabled.

The free voltage digital inputs are programmable by the **i1F** and **i2F** parameters.

9.1. ON - OFF Function

Switches the controller ON and OFF.

9.2. Digital Inputs Polarity

The digital input polarity depends on the **i1P** and **i2P** parameters.

- **i1P or i2P = CL**: the input is activated by closing the contact.
- **i1P or i2P = oP**: the input is activated by opening the contact.

10 Installation and Mounting

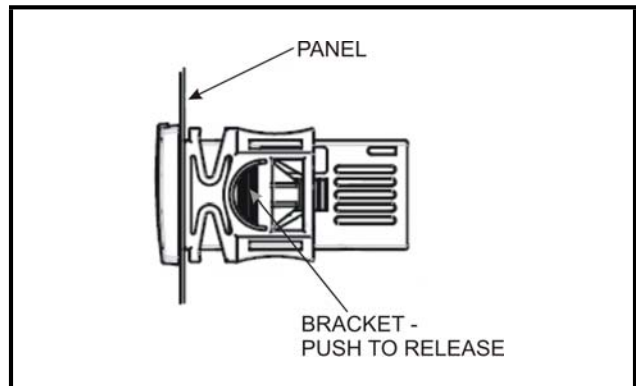

Figure 10-1 - Installation and Mounting of XR75CX-CD

The XR75CX-CD controller should be mounted on a vertical panel, in a 29 mm x 71 mm hole, and secured using the special bracket supplied.

The temperature range allowed for correct operation is 0 to 60°C. Avoid places subject to strong vibrations, corrosive gases, excessive dirt, or humidity. The same recommendations apply to probes. Allow air to circulate through the cooling holes.

11 Electrical Connections

The device is provided with screw terminal block to connect cables with a cross section up to 2.5 mm². Before connecting cables verify that the power supply complies with the device's requirements. Separate the probe cables from the power supply cables, from the outputs and the power connections. Do not exceed the maximum current allowed on each relay, in case of heavier loads use a suitable external relay.

11.1. Probe Connection

The probes should be mounted with the bulb upwards to prevent damages due to casual liquid infiltration. It is recommended the thermostat probe be placed away from air streams to measure the average room temperature correctly. Place the defrost termination probe among the evaporator fans in the coldest place, (where most ice is formed) and far from heaters or from the warmest place during defrost to prevent premature defrost termination.

12 Hot Key



NOTE: The Hot Key function is not used on XR75CX-CD.

13 Specifications

Dimensions	Case: Front: 32 mm x 74 mm Depth: 60 mm
	Panel Mount: 71 mm x 29 mm panel cut-out
Housing	Self extinguishing ABS
Protection	IP 20
	Frontal: IP65
Connections	Screw terminal block $\leq 2.5 \text{ mm}^2$ wiring
Power Supply (depending on the model)	230VAC $\pm 10\%$, 50/60Hz 110VAC $\pm 10\%$, 50/60Hz
Power Absorption	3VA max
Display	3 digits, red or blue LED, 14.2 mm high
Inputs	Up to four (4) NTC or PT1000 probes
	Digital: free voltage contact
Relay Outputs	03: 120/240 5A 250VAC
	02: N.O./N.C- 120/240 10A 250VAC
	01: 120/240 4.9FLA, 29.4 LRA, 10A 250VAC
	04: 120/240 ¼ HP, 10A 250VAC
Data Storing	On the non-volatile memory (EEPROM)
Rated Impulsive Voltage	2500V
Overvoltage Category	II
Temperatures	Operating: 0 to 55°C
	Storage: -30 to 85°C
Relative Humidity	20 to 85% (no condensing)
Resolution	0.1°C or 1°C or 1°F (selectable)
Accuracy (ambient temperature 25°C)	$\pm 0.7^\circ\text{C} \pm 1$ digit

Table 13-1 - XR75CX-CD Specifications

14 Connections

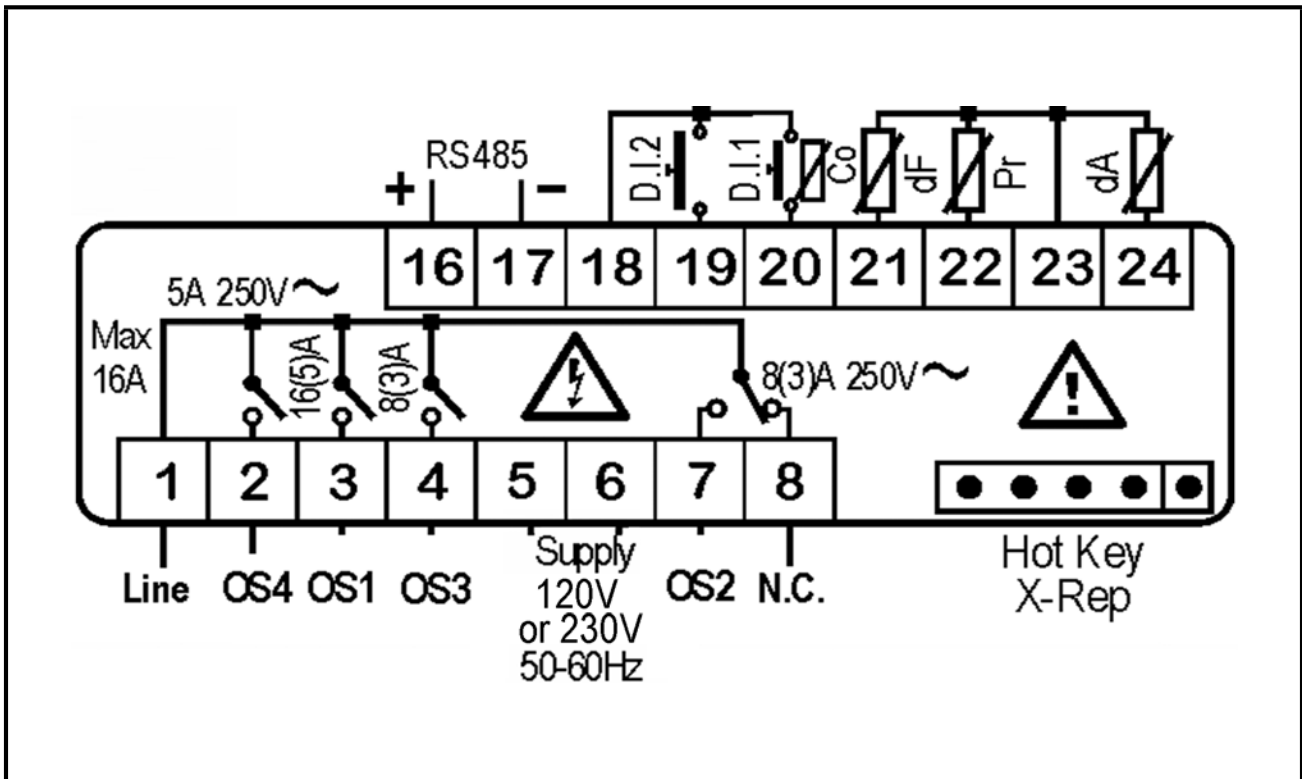

Figure 14-1 - XR75CX-CD Connections

NOTES: 120V or 230V depending on the model.
 The Hot Key function is not used on the XR75CX-CD.

15 E2 MODBUS Network Wiring

- Connect the MODBUS Network to the RS485 Connector on the E2 PIB board (Belden 8641 recommended).
- Note to wire the RS485 +/- polarity at the E2 in the *reverse* of the XR75CX-CD devices.
- Position the three termination jumpers to the UP (terminated) position to provide RS485 termination at the E2.
- Do not connect the shield of the MODBUS network to the E2 PIB center terminal. Instead, use a 100 ohm 1/2 watt resistor to connect the MODBUS cable shield to earth ground.
- At each XR75CX-CD device, wire the MODBUS cable to the RS485 +/- terminals and connect the MODBUS shield to the pin 18 terminal.
- Terminate the end of the MODBUS network at the last XR75CX-CD device on the daisy chain with the MODBUS termination block (P/N 535-2711), or by connecting a 150 ohm resistor between the MODBUS +/- terminals.

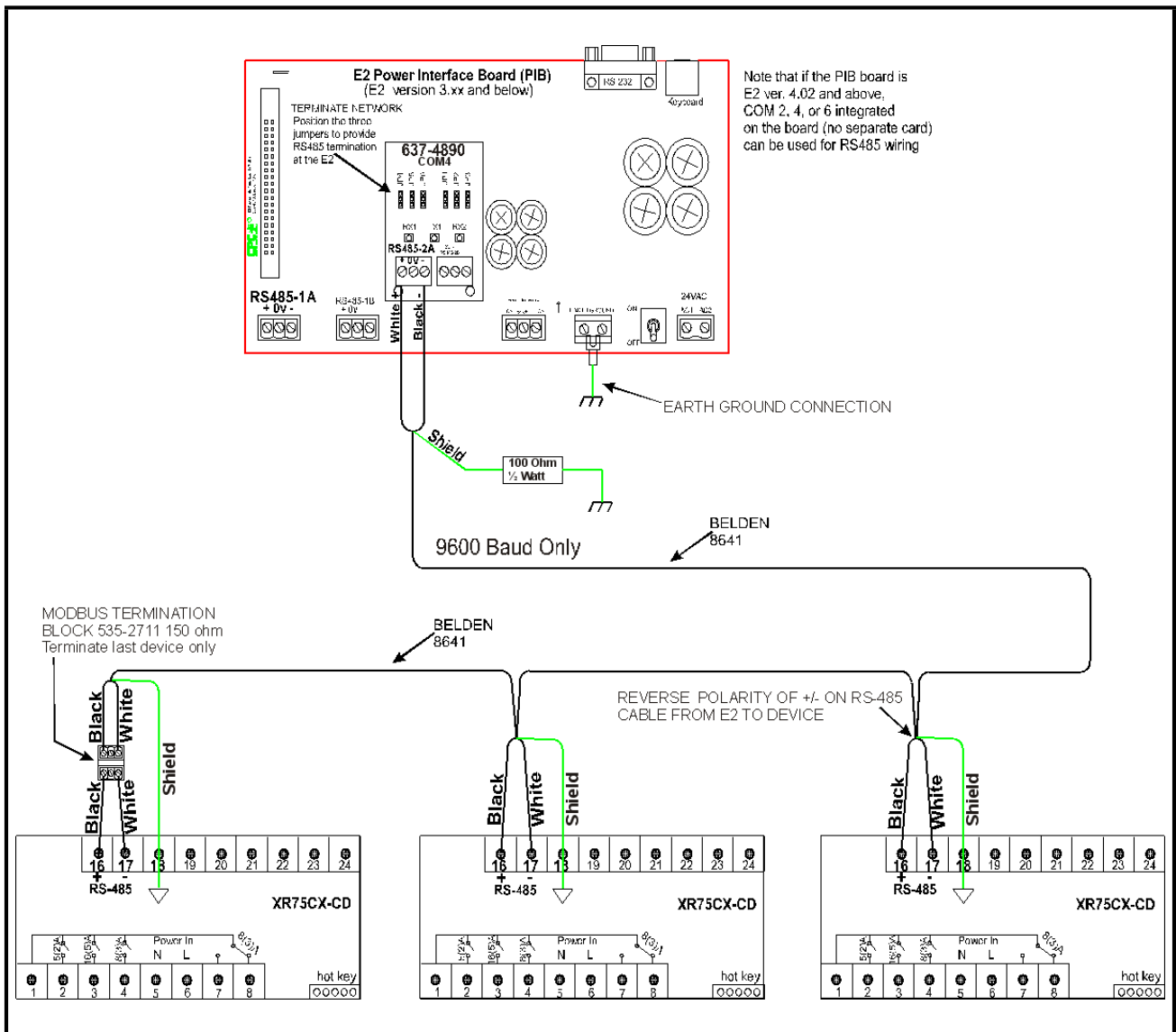

Figure 15-1 - XR75CX-CD to E2 MODBUS Network Wiring

16 ECT MODBUS Networking to E2s

16.1. COM Port Associations - E2 Versions 3.xx and Below

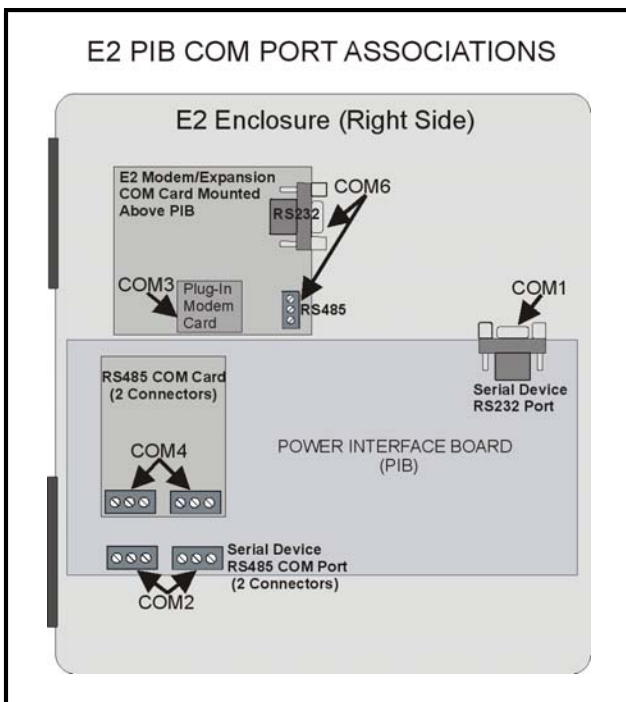

Figure 16-1 - Location of E2 Com Ports (E2 versions 3.xx and Below)

Connecting a XR75CX-CD controller to an E2 requires the E2 to be version 3.02 or above. Contact Retail Solutions for upgrade information if the controller is a version before 3.02.

An E2 has up to three COM ports that can be assigned for MODBUS communication: COM2, an RS485 port on the E2 power interface board, and COM4 and COM6, which are optional ports requiring expansion cards. COM4 is recommended for MODBUS connection of XR75CX-CD units.

COM ports can only be used for one function; in other words, if COM2 is set up as the I/O network, you cannot connect MODBUS devices to COM2. En-

sure your E2 is equipped with an RS485 COM Card (P/N 637-4890) and configured in E2 General Services (Menu **7 3 1**, **Serial** tab) to enable COM4 or an E2 Expansion COM Card (P/N 637-4871) to enable COM6.

Connect the MODBUS network cable to the three-terminal connector on the COM port you wish to assign as MODBUS. Reverse polarity of +/- on RS485 cable from E2 to the device.

16.2. COM Port Associations - E2 Versions 4.2 and Above

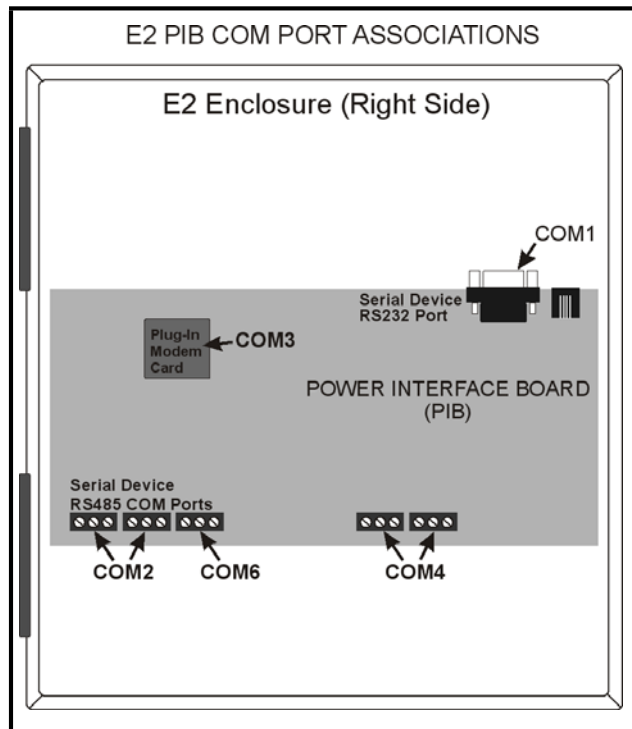

Figure 16-2 - Location of E2 COM Ports - E2 PIB Board (E2 version 4.2 and above)

An E2 has three COM ports that can be assigned for MODBUS communication (COM2). COM ports can only be used for one function; in other words, if COM2 is set up as the I/O network, you cannot connect MODBUS devices to COM2. Ensure your E2 is configured in E2 General Services (Menu **7 3 1**, **Serial** tab) to enable COM4 or COM6.

Connect the MODBUS network cable to the three-terminal connector on the COM port you wish to assign as MODBUS. Reverse polarity of +/- on RS485 cable from E2 to the device.

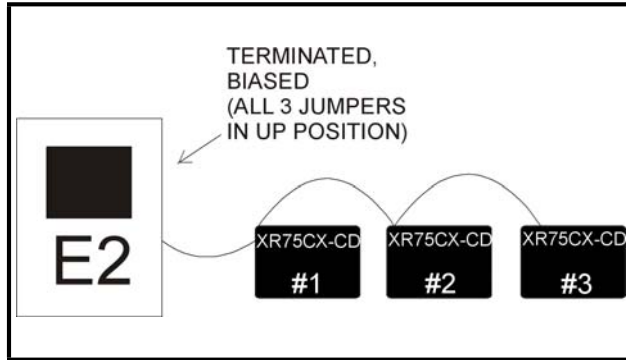

Figure 16-3 - MODBUS Networking

16.3. E2 Setup of Devices

16.3.1. Set Up Network Ports

Before setting up a device, the port on the E2 that has the MODBUS cable connected must be set up as a MODBUS port.

1. Log in to the E2 with Level 4 access.
2. Press **Menu** followed by **&7#31** - **General Controller Info**.
3. Press **Ctrl + 3** to open the **Serial** tab of the General Controller Info setup screens:

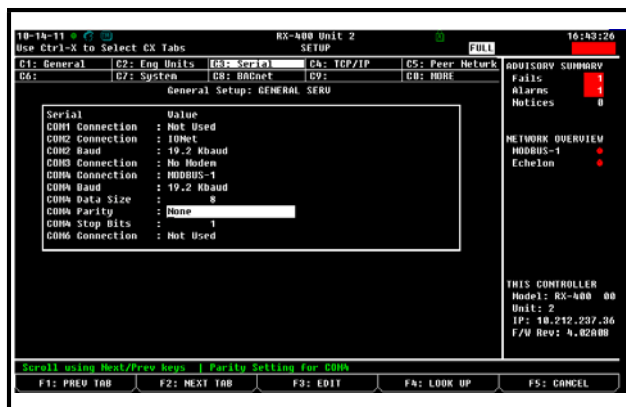

Figure 16-4 - Serial Communications Manager Screen

4. This screen will have a "Connection" field for all COM ports on the E2. Highlight the COM port connection field that will be used

for the device, and press **F4** - **LOOK UP**. From the list of network types, select **MODBUS**.

5. Four fields will become visible underneath the COM port connection field, which pertain to the way the device communicates:

- **Baud** - Default setting is **19200**. The baud rate setting should be set to match the baud rate of the XR75CX-CD device. (All devices connected to the same COM port should be set to the same baud rate.)
- **Data Size** - Leave this field at the default value (**8**).
- **Parity** - Leave this field at the default value (**None**).
- **Stop Bits** - Leave this field at the default value (**1**).

6. Press **Esc** to save changes and exit.

16.3.2. Add and Connect the Device

To enable communications between E2 and the XR75CX-CD units, the devices must be added and addressed in E2.

1. Log in to the E2 with Level 4 access.
2. Press **Menu** & **&7#7@2** - **Connected I/O Boards and Controllers**.

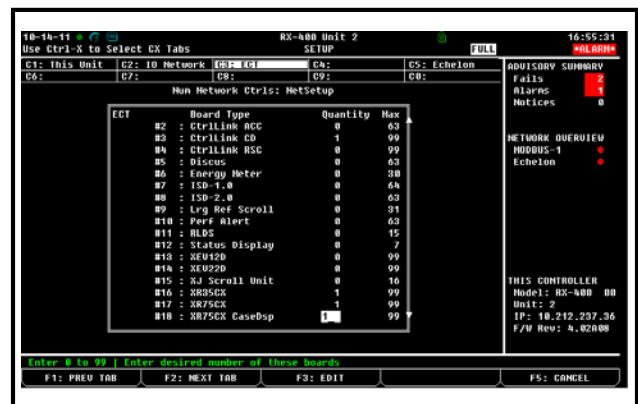

Figure 16-5 - Num NetworkCtrls: NetSetup Screen

3. In the **Num NetworkCtrls: NetSetup** screen, under the **ECT** tab, enter the number of devices in the **Quantity** field. (**Max** shows the maximum number of devices allowed on the network.)
4. Press **Esc** to return to the **Network Setup** menu, then select **1** - **Network Summary**.
5. Locate the units you added to the network list (press **Page Up** and **Page Down** to scroll through the list). If desired, enter a new name for each device in the **Name** field.

the following messages:

- **Online** - The device is communicating normally.
- **Offline** - The device is not communicating, has not been commissioned, is not functional, or is not powered up. Verify the device is powered up, wired correctly, and has the proper network address, baud rate, and parity.
- **Unknown** - The device is not communicating or has not been commissioned. Verify the device is powered up, wired correctly, and has the proper network address, baud rate, and parity.
- **No Port** - No port is set up in the E2 Serial Configuration Manager to be a MODBUS port.
- **Wrong FW Rev** - This message is likely caused by the device having a firmware version older than the minimum revision required by E2 for communication. Replace the device with a new one or a device that has the latest version of firmware on it.

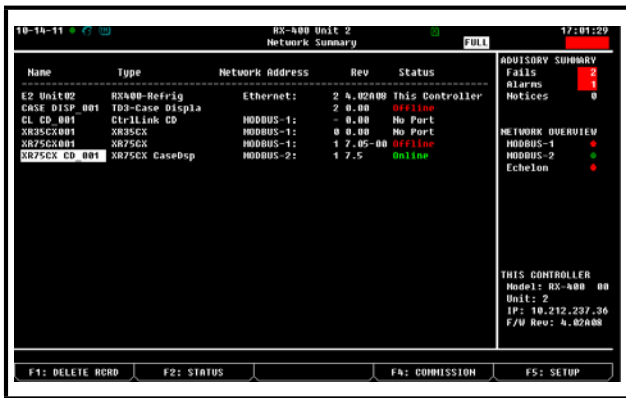

Figure 16-6 - Network Summary Screen

- By default, each device in the network list has a board number of 0. To set the address and begin communication, choose the device and press **F4**. In the list of MODBUS devices, choose the address number corresponding to the XR75CX-CD address set up through the front display, and press **Enter** to select it. A window will open where you can specify the address of the controller. If a network ID has already been selected, its name will be shown next to the network ID in this list. If the network ID you are trying to assign has already been used, you must set the address on this device to a different number that is not being used.

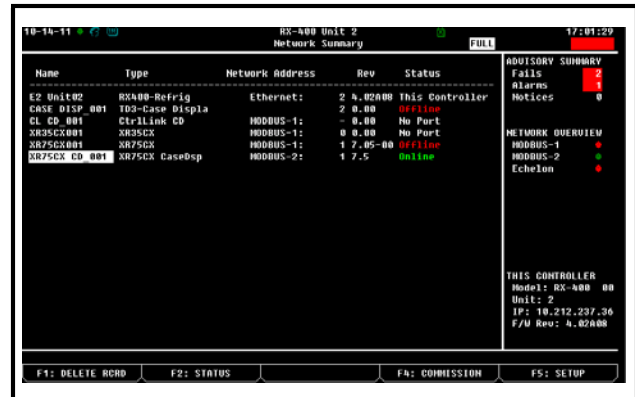

Figure 16-8 - Network Summary Screen

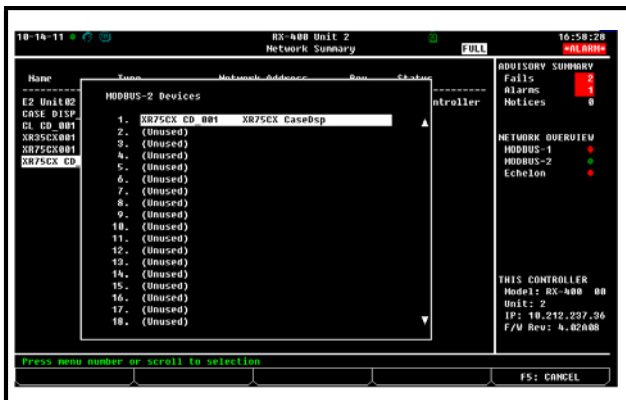

Figure 16-7 - List of MODBUS Devices

- Repeat **Steps 5** and **6** until each device has a name and address.
- When finished, press **ESC** to return to the **Network Setup** menu, then press **1** - **Network Summary** (Figure 16-6). Locate the devices you set up, and look at each device's status in the **Status** field. You will see one of

16.4. Wiring Types

Retail Solutions specifies Belden #8761 shielded twisted pair cables for use as MODBUS wiring (or Belden #82761 and Belden #88761 for plenum installations).

For MODBUS network wiring of XR75CX-CD controllers to E2, Belden #8641 (*P/N 135-8641*) is the recommended wire type to use.

If the recommended cable is not available in your area, be sure the wiring meets or exceeds the following specs:

Shielded?	Yes
Conductor Type	Twisted Pair
Gauge	18 - 24 AWG
Capacitance between signal wires	31 pF/ft or less (9.45 m) or less
Capacitance between signal and shield	59 pF/ft or less (17.98 m) or less
Maximum Length	4000 ft/18 to 22 AWG (1219.2 m) 2500 ft/24 AWG (762 m)
Nominal Impedance	120W±50W

16.5. MODBUS Termination Blocks

Because the XR75CX-CD device has no on-board means of termination, use the MODBUS termination block (*P/N 535-2711*) for termination that can be wired to the end of the cable segment using the three-pin connector. Wire the two signal wires to the outside terminals, and connect the shield to pin **18** of the device, keeping the exposed shield wire length as short as possible (3 inches ideal maximum length).

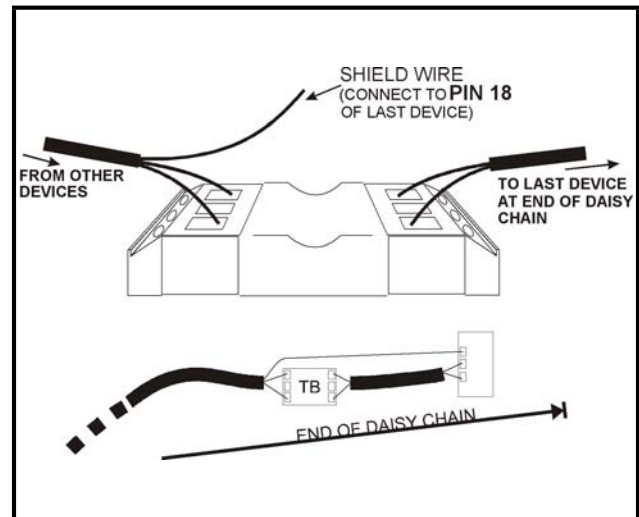

Figure 16-9 - MODBUS Termination Block (*P/N 535-2711*)

The contents of this publication are presented for informational purposes only and they are not to be construed as warranties or guarantees, express or implied, regarding the products or services described herein or their use or applicability. Computer Process Controls, Inc. reserves the right to modify the designs or specifications of such products at any time without notice. Computer Process Controls, Inc. does not assume responsibility for the selection, use or maintenance of any product. Responsibility for proper selection, use and maintenance of any Computer Process Controls, Inc. product remains solely with the purchaser and end-user.

026-1217 08-NOV-2011 Emerson is a trademark of Emerson Electric Co. ©2011 Computer Process Controls, Inc. All rights reserved. Printed in the USA.