

PLEXI DIVIDER FIELD INSTALLATION FOR REVEAL MERCHANDISER®

Instructions for field-installing a plexi-divider between Reveal Merchandiser® cases.

KIT INCLUDES: PLEXI DIVIDER, BRACKET, WASHERS, NUTS, AND SCREWS

1. On the left case, locate and remove the three screws on the right end of the case ceiling (FIGURE 1).
2. Install the plexi divider bracket using the same screws (FIGURE 2).
3. Remove protective film from the top of the plexi divider (about 6"). Position it on the right side of the bracket so the joining holes match (FIGURE 3).
4. Use the provided washers, nuts, and screws to install the plexi divider to the bracket (FIGURE 4). **Tighten until snug; do not overtighten.** Once the plexi divider is installed, remove the rest of the protective film.

Part Number	Description	Quantity
34-0120-(X)	Plexi Divider	1
34-0121-P(X)	Plexi Divider Bracket	1
64-0201	Washer	6
64-0208	Nut	3
64-0310	Screw	3

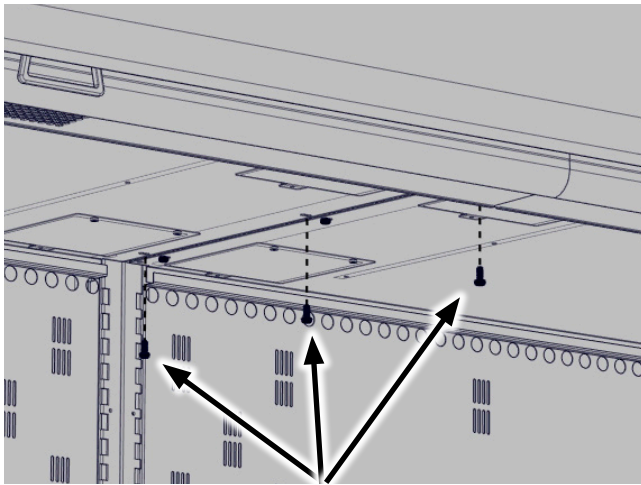

FIGURE 1: Remove Screws from Right Side of Left Case Ceiling

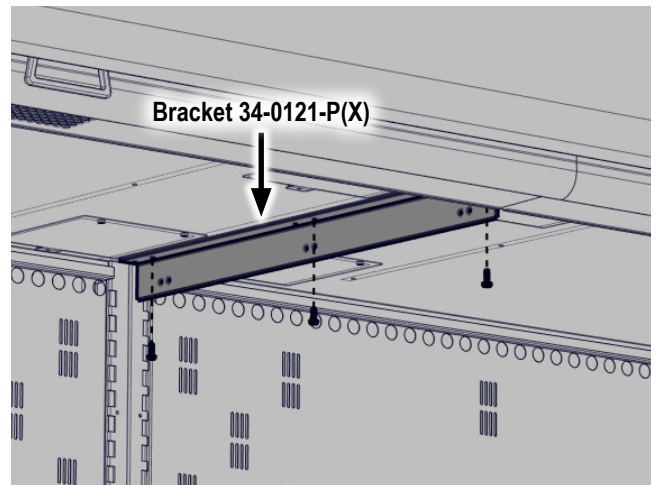

FIGURE 2: Install Bracket Using Screws

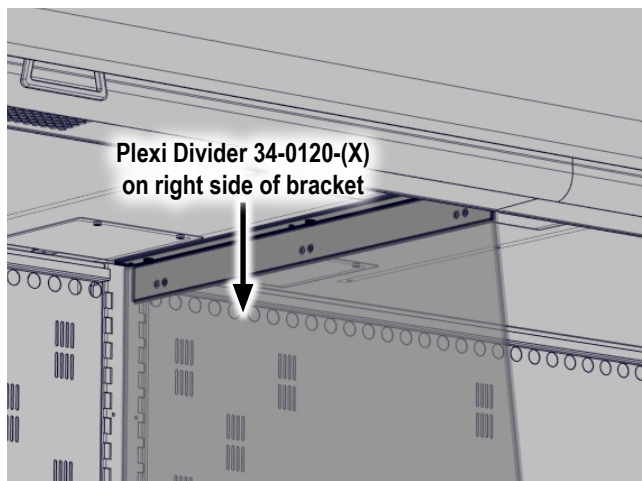

FIGURE 3: Remove Protective Film from Plexi Divider and Then Position It

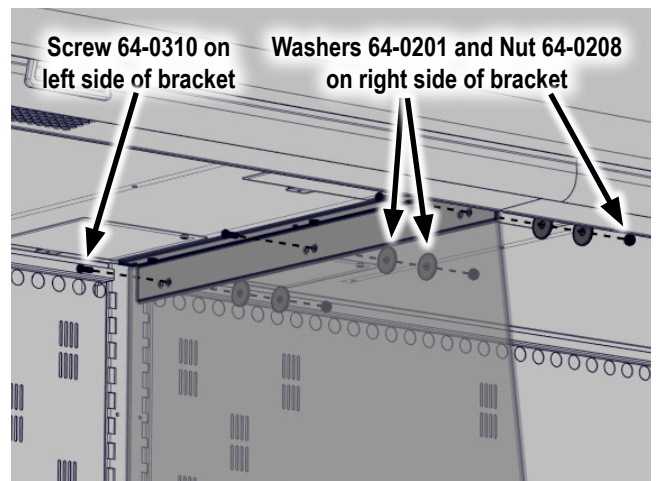

FIGURE 4: Install Plexi Divider Using Washers, Nuts, and Screws

